



VIRA REUNIONES

Su pata inclinada, tanto de madera como metálica, como seña de identidad y los acabados que conviven perfectamente entre sí, hacen de esta mesa un mobiliario de formas amables que sigue la estética del mercado actual.



PRESTACIONES OPCIONALES

CANAL ELECTRIFICACIÓN

- ▶ Canal mesas componibles con 2 posiciones en altura

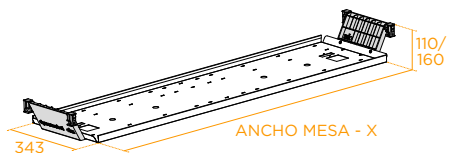

Mesa intermedia X= 268
Mesa inicial / final X= 468

Tapas laterales ABS en color BA con estructura BA.
En color NE para resto de colores estructura.

BANDEJA

- ▶ Metálica e= 0,8 mm
Bandeja mesas independientes

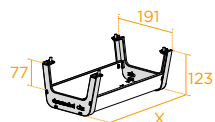

Tapa abatible lateral X= 334
Tapa abatible 400 X= 509
Tapa abatible 800 X= 909

Tapas laterales ABS en color BA con estructura BA.
En color NE para resto de colores estructura.

FICHA TÉCNICA



PRESTACIONES OPCIONALES

ACCESOS CANAL

- ▶ Tapa abatible lateral *
Metálica o igual acabado tablero
Marco perimetral 2 mm NE
Opción enchufes integrados

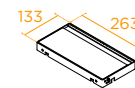

- ▶ Pasacables Ø 60 *
Color BA y NE



- ▶ Tapa abatible central (doble giro) **
Metálica o igual acabado tablero
Marco perimetral 2 mm NE

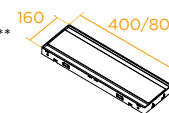

- ▶ Base multiconexión Ø 60 **
Color BA y NE
1F + 1USB A + 1 USB C
+ 20 cm cable acabado wíeland



* Acceso BA: Tablero BA - Acceso NE: Resto tableros ** Según pedido

Posicionamiento:

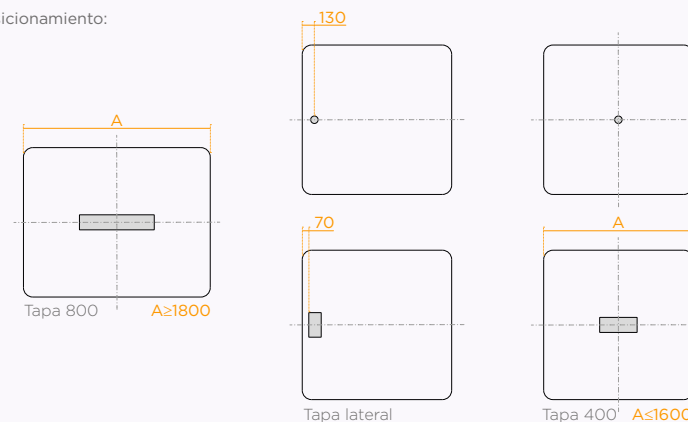

SUBIDA CABLEADO

- ▶ Malla

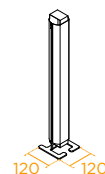

- ▶ Vertebrada



- ▶ Totem

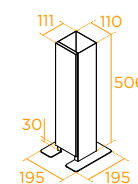

- ▶ Tapa registrable en pata intermedia

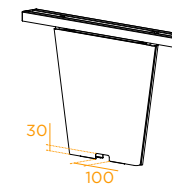

Chapa espesor 1 mm pintada





VIRA REUNIONES



DESCRIPCIÓN

TABLERO

Tablero en aglomerado de partículas de madera de 25 mm de espesor, encolado con resinas sintéticas y especialmente diseñado para aplicaciones que requieran alta resistencia a la flexión. Densidad media 620/595 kg/m³ según norma EN 323.

- ▶ Acabado laminado, canto de ABS de 2 mm de espesor según norma UNE 56.843:01.
- ▶ Acabado en estratificado de alta densidad (HPL) antihuellas, en la cara superior e-0,7 mm según lo indicado en la norma UNE 53173-92 y un contratiro (BM80) en la inferior. El canto de ABS de 2 mm de espesor según norma UNE 56.843:01.
- ▶ Acabado en madera con tratamiento de barnizado en alta resistencia. Canteado en madera de 2 mm de espesor.

ESTRUCTURA

Bastidor metálico construido con 2 perfiles de acero de 50x30 espesor 1,5 mm según norma UNE-EN 10305.

Pata extremo construida con travesaño superior de acero de 50x30 espesor 1,5 mm según norma UNE-EN 10305, y bajante a suelo. Opción chapa espesor 1,5 mm conformada o en madera de haya rechapada en roble. Opción rueda con freno d-65 mm.

Pata intermedia metálica en los puestos agrupados, construida con bajantes inclinadas de perfil 50x30 espesor 1,5 mm y 2 perfiles 50x30 espesor 1,5 mm según norma UNE-EN 10305, soldados a la bajante.

Pintura en polvo epoxi de 60/80 micras que cumple la normativa vigente de reacción al fuego UNE 23827-90.

Nivelación patas 20mm.

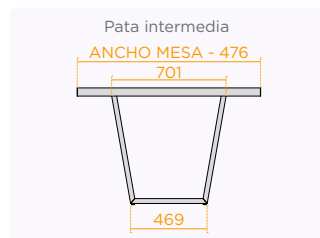
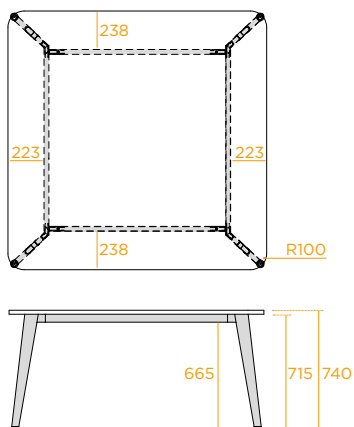

FICHA TÉCNICA



DETALLES



▲ TAPA ABATIBLE
Lateral



▲ TAPA ABATIBLE
Central (doble giro)



▲ ACCESO CANAL
Base multiconexión Ø 60



▲ CANAL



▲ BANDEJA



▲ PATA INTERMEDIA
Con tapa registrable



CERTIFICADOS





VIRA REUNIONES

FICHA TÉCNICA



GAMA

MESA INDEPENDIENTE

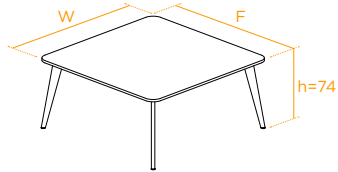

W \ F	100	120	140	160	180	200	220	240
80	● ▲ ■	● ▲ ■	● ▲ ■	● ▲ ■	● ▲ ■	● ▲ ■		
90	●	●	●	●	●	●		
100	●	●	●	●	●	●	●	
120		● ▲ ■	● ▲ ■	● ▲ ■	● ▲ ■	● ▲ ■	● ▲ ■	● ▲ ■
140			●	●	●	●	●	●
160				● ▲ ■	● ▲ ■	● ▲ ■	● ▲ ■	● ▲ ■

MESA COMPONIBLE

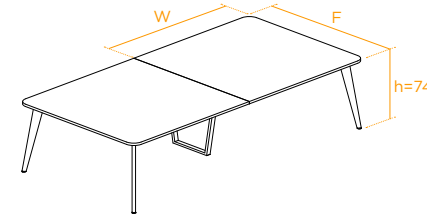

W \ F	120	140	160	180	200	220	240
120	●	●	●	●	●	●	●
140		●	●	●	●	●	●
160			●	●	●	●	●

MESA REDONDA

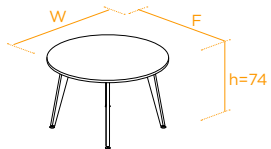

W \ F	100	120	140	160
100	●			
120		●		
140			●	
160				●

MESA TRIANGULAR

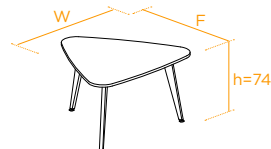

W \ F	120	140	160
120	●		
140		●	
160			●

MESA TRAPEZOIDAL

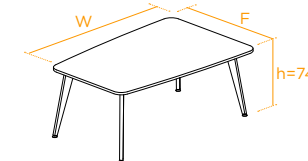

W \ F	120	140	160	180	200	220	240
120	●	●	●	●	●	●	●
140		●	●	●	●	●	●
160			●	●	●	●	●

LEYENDA

CONDICIONES DE TARIFA

- GENERAL
- EXPRESS

OPCIONES DISPONIBLES

- Con ruedas (sólo pata metálica)
- ▲ h=90/105





MESA BARRIL

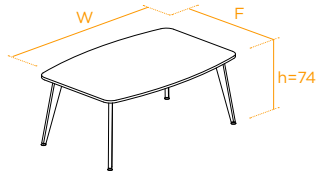

W \ F	180	200	220	240
120	●	●	●	●
140	●	●	●	●
160	●	●	●	●

MESA TRES LADOS

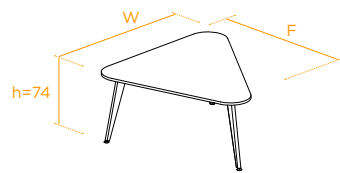

W \ F	160
160	●

MESA CUATRO LADOS

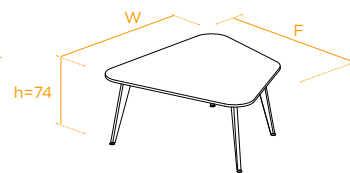

W \ F	160
160	●

MESA CINCO LADOS

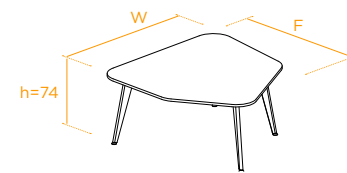

W \ F	160
160	●

MESA SEIS LADOS

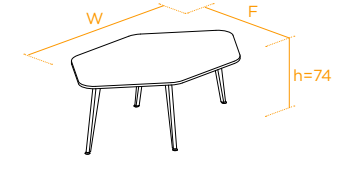

W \ F	200	240
120	●	●

MESA ELIPTICA

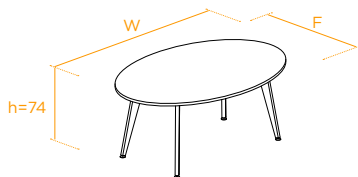

W \ F	180	200	220	240
120	●	●	●	●
140	●	●	●	●
160	●	●	●	●

MESA TRAPEZOIDAL T2

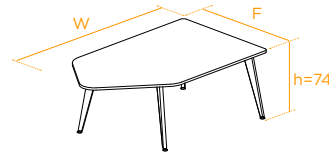

W \ F	160	200	240
120	●	●	●
160	●	●	●

MESA TRAPEZOIDAL DOBLE T2

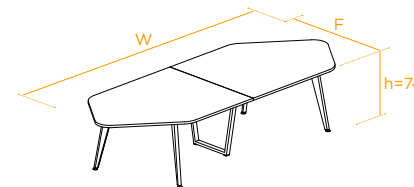

W \ F	320	400	480
120	●	●	●

MESA BARRIL DOBLE

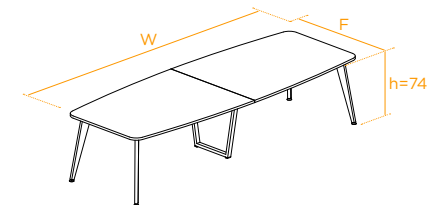

W \ F	320	400	480
120	●	●	●
140	●	●	●
160	●	●	●

LEYENDA

CONDICIONES DE TARIFA

- GENERAL
- EXPRESS

OPCIONES DISPONIBLES

- Con ruedas (sólo pata metálica)
- ▲ h=90/105

